

Installation Guide

GCX Wall Channel Installation Guide for Seismic and Non-Seismic Applications



Warnings

- Installation must be performed by Qualified Personnel. Failure to follow these Instructions may result in serious injury.
- Instructions and the illustrations covering the specific instrument to be mounted should be reviewed prior to Installation of Wall Channel.
- It shall be the responsibility of the hospital, its consultants and/or contractors to determine that the wall is adequate to safely mount instrumentation. This includes the selection of appropriate fasteners and the proper installation of the same.
In new construction and remodeling work where the wall covering can be entirely or partly removed, a 16-gauge steel stud/plate or a 2" X 6" Douglas Fir #2 stud should be located for the purpose of attaching the Wall Channel. The following is provided as guideline information only.
- Do not substitute or omit fasteners.
- Do not position any mounts or related hardware above a patient.
- Allow clearance on either side of the Channel centerline to clear objects such as over-bed lighting, privacy curtains, adjacent walls or columns, door swing arcs, etc. Power and signal outlets should be considered when selecting a channel location. Avoid oxygen, vacuum and air outlets.
- Ensure that the weight being mounted does not exceed Load Ratings.
- Although considerable effort has been made to ensure the safety of the above installation and/or Guidelines, the actual wall construction materials and installation itself is beyond the control of GCX Corporation. Accordingly, GCX Corporation is not responsible for the failure of any such installations.

OSHPD

The GCX 13" (33 cm), 19" (48.3 cm), 25" (63.5 cm), 31" (79 cm), 37" (94 cm) and 49" (124.4 cm) Seismic Channels conform to the California Office of Statewide Health Planning and Development (OSHPD) Seismic Preapproval requirements. **Refer to our website, www.gcx.com/support, to obtain the latest available documentation.**

Locating the Wall Channel

Note: Devices and Wall Mounts may require channel placement outside of these guidelines. Access to device controls, ergonomic requirements, and the "range of motion" the Mount provides should be considered before mounting the Wall Channel.

Displays and Patient Monitors: The bottom edge of a 19" (48.3 cm) Wall Channel is placed 54" (142.2 cm) above the floor, plus or minus 4" (10.2 cm).

Computer Workstations: When mounting a computer workstation with a VHM Series Arm, the bottom edge of a 19" (48.3 cm) Wall Channel is placed 37.5" (95.2 cm) above the floor. When using M Series Arms, the bottom edge of the 19" (48.3 cm) Wall Channel is placed 26.5" (67.3 cm) above the floor.

Seismic Wall Channel

The following Wall Channel parts reference chart lists hardware quantities for the 19" (48.3 cm) Seismic Wall Channel. Longer channels are available and include hardware for the additional mounting points.

Seismic Wall Channel Parts Reference

Item #	Description	Qty
1	#10 x 2" Oval Head Sheet Metal Screw (OHSMS)	7
2	#10 x 2" Pan Head Sheet Metal Screw (PHSMS)	3
3	Fixed Channel Stop	1
4	10-32 x 3/8" Flat Head Machine Screw (FHMS)	1
5	Depressible Channel Stop	1
6	Seismic Wall Channel	1

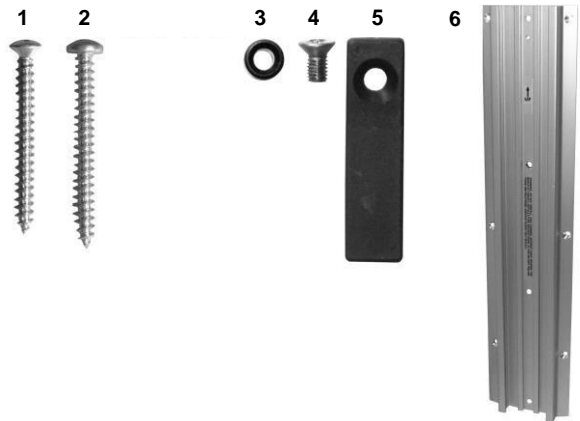

Installing Seismic Wall Channel

Drill all screw holes in the 16-gauge or Douglas Fir anchorage using a 9/64" diameter twist drill bit for the #10 x 2" type "A" sheet metal screws supplied. Do not substitute screws. Install the top, centerline screw first. Level the channel and mark for the remaining 9 screws. The (3) Pan Head Screws are used in the 3 centerline holes. The bottom Fixed Stop, and all others holes use Oval Head Screws. Screws should be started and driven with ball handle drivers or torque limiting screw guns not exceeding 60 inch-pounds (6.7 Nm).

Channel Placement Recommendation

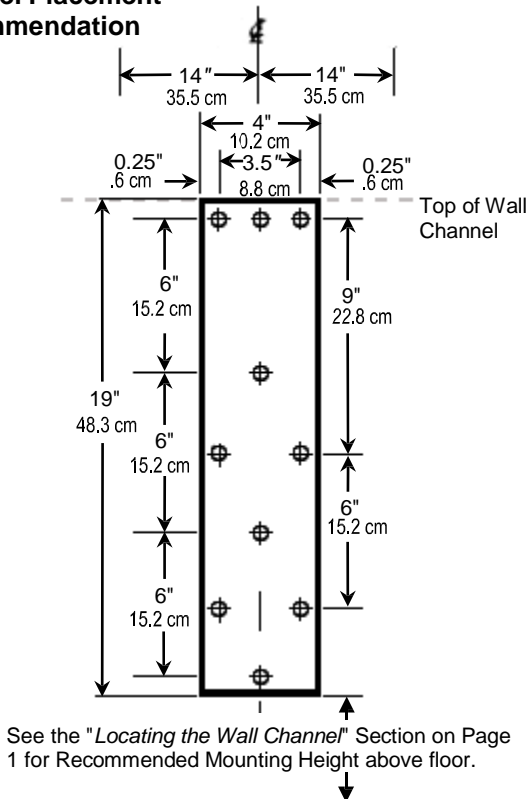

Hardware Placement

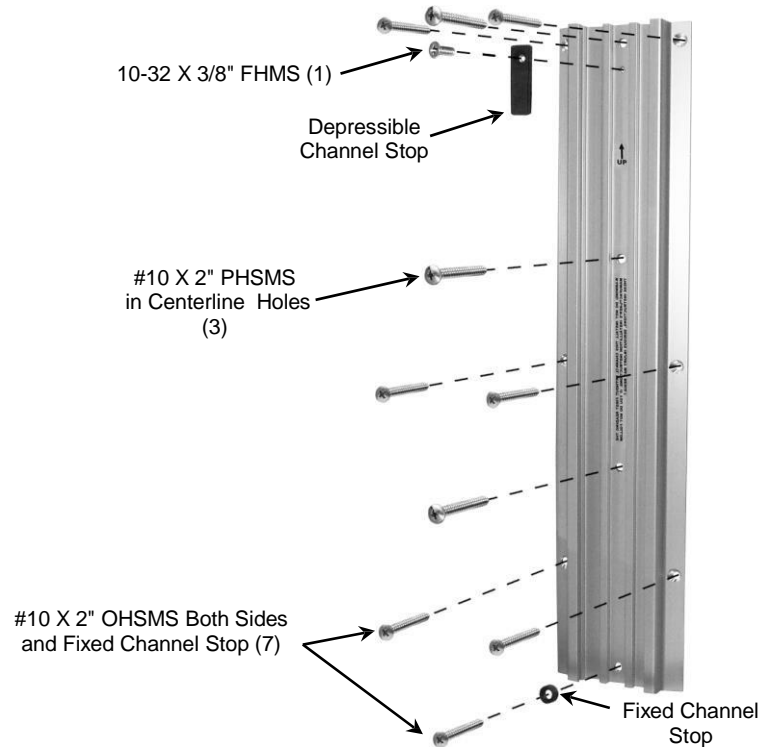

Seismic Wall Channel Support Backing Methods

The recommended two inner wall backing materials and methods are: 16-gauge stud or plate for steel framed walls, or 2" x 6" solid Douglas Fir blocking for wood framed walls. **Note: the inner wall framing structure needs to be designed and verified by the structural engineer of record to support the applied weights and forces on wall.**

METHODS OF SUPPORT BACKING

Steel stud walls

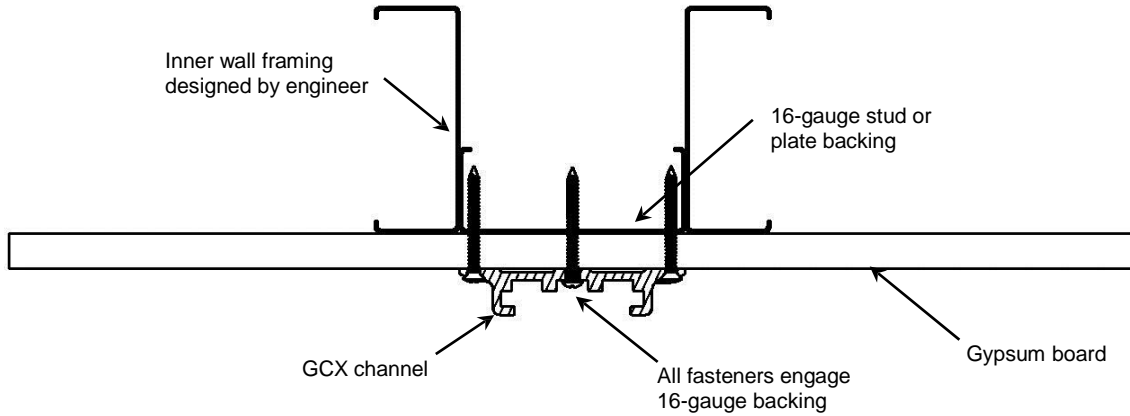

Wood stud walls

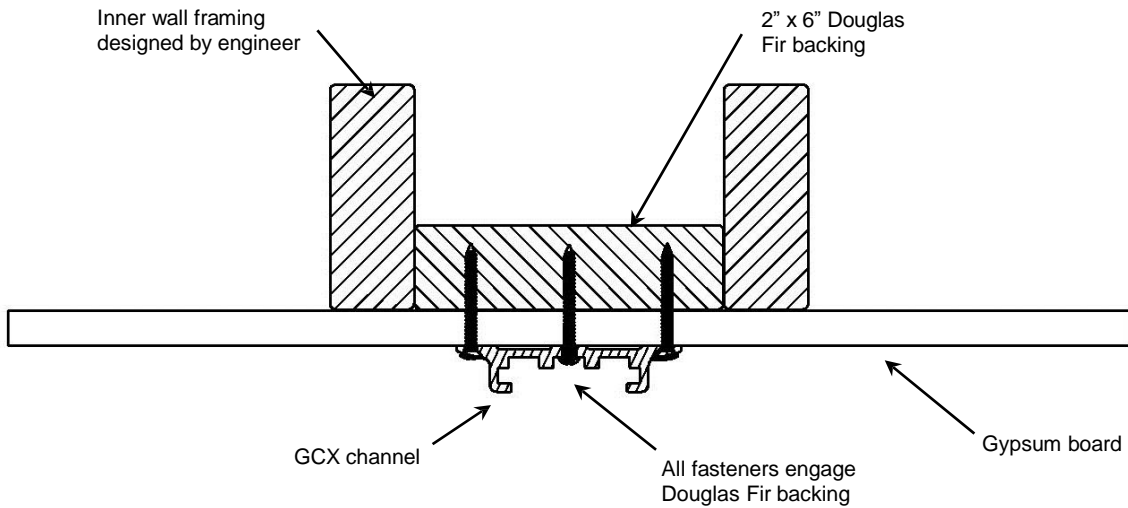

Standard Wall Channel

The following Wall Channel parts reference chart lists hardware quantities for 19" (48.3 cm) Standard Wall Channel. Longer channels are available and include hardware for the additional mounting points.

Standard Wall Channel Part Reference

Item #	Description	Qty
1	#12 x 2 3/4" Sheet Metal Screw (SMS)	4
2	1/4-20 x 3" Pan Head Machine Screw w/Toggle Wings	4
3	Fixed Channel Stop	1
4	10-32 x 3/8" Flat Head Machine Screw (FHMS)	1
5	Depressible Channel Stop	1
6	Standard Wall Channel	1



Installing the Standard Wall Channel

Drill 11/64" (17 mm) diameter holes for #12 X 2-3/4" high tensile Philips Head Screws. Install the top screw and level the channel, then mark and drill the other holes. Screws should be started and driven with ball handle drivers or torque limiting screw guns not exceeding 60 inch-pounds (6.7 Nm). Screws must pass through Channel, drywall, and fully engage with wood stud or 16-gauge steel stud.

Drill 3/4" (19.5 mm) diameter holes for the 1/4-20 x 3" Pan Head Machine Screws with Toggle Wings. Toggle wings should be used if steel wall stud is less than 16-gauge in thickness.

Installation Note: Seismic Wall Channel can be installed in the same manner as a Standard Wall Channel when OSHPD approval is not required.

Channel Placement Recommendation

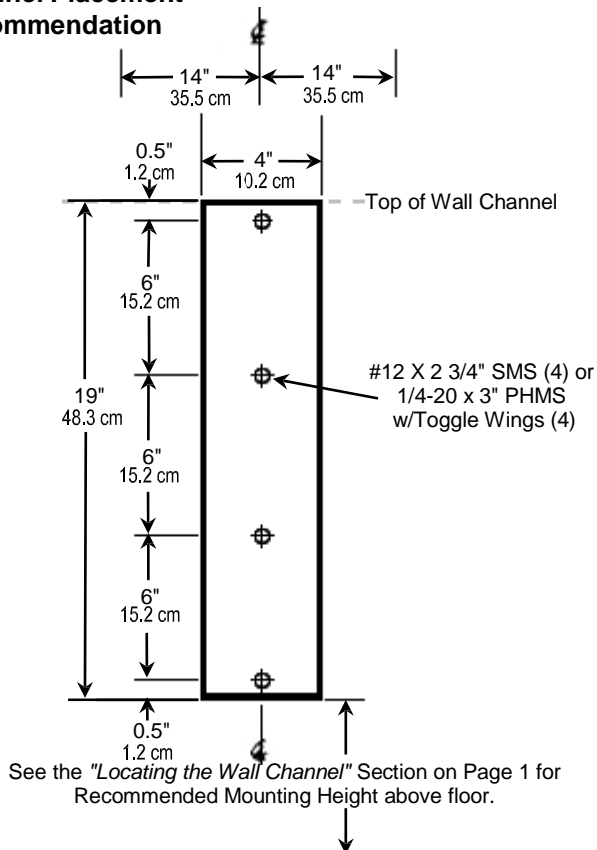

Hardware Placement

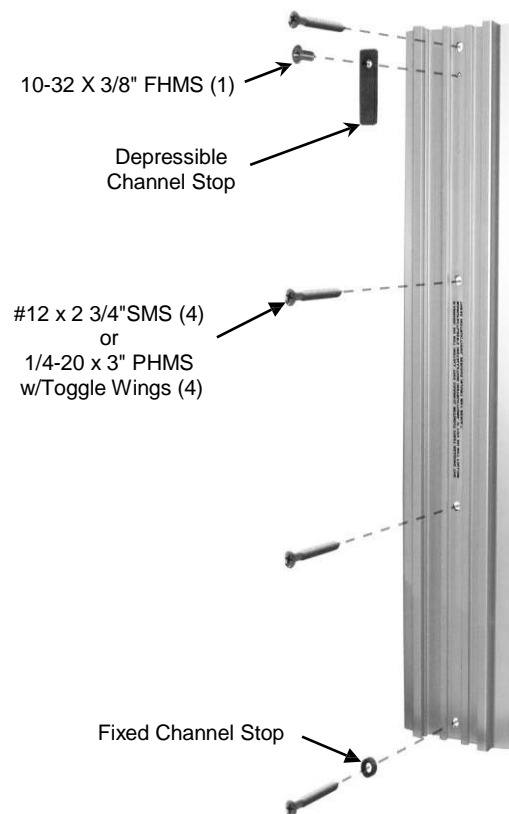

Method-A

Standard

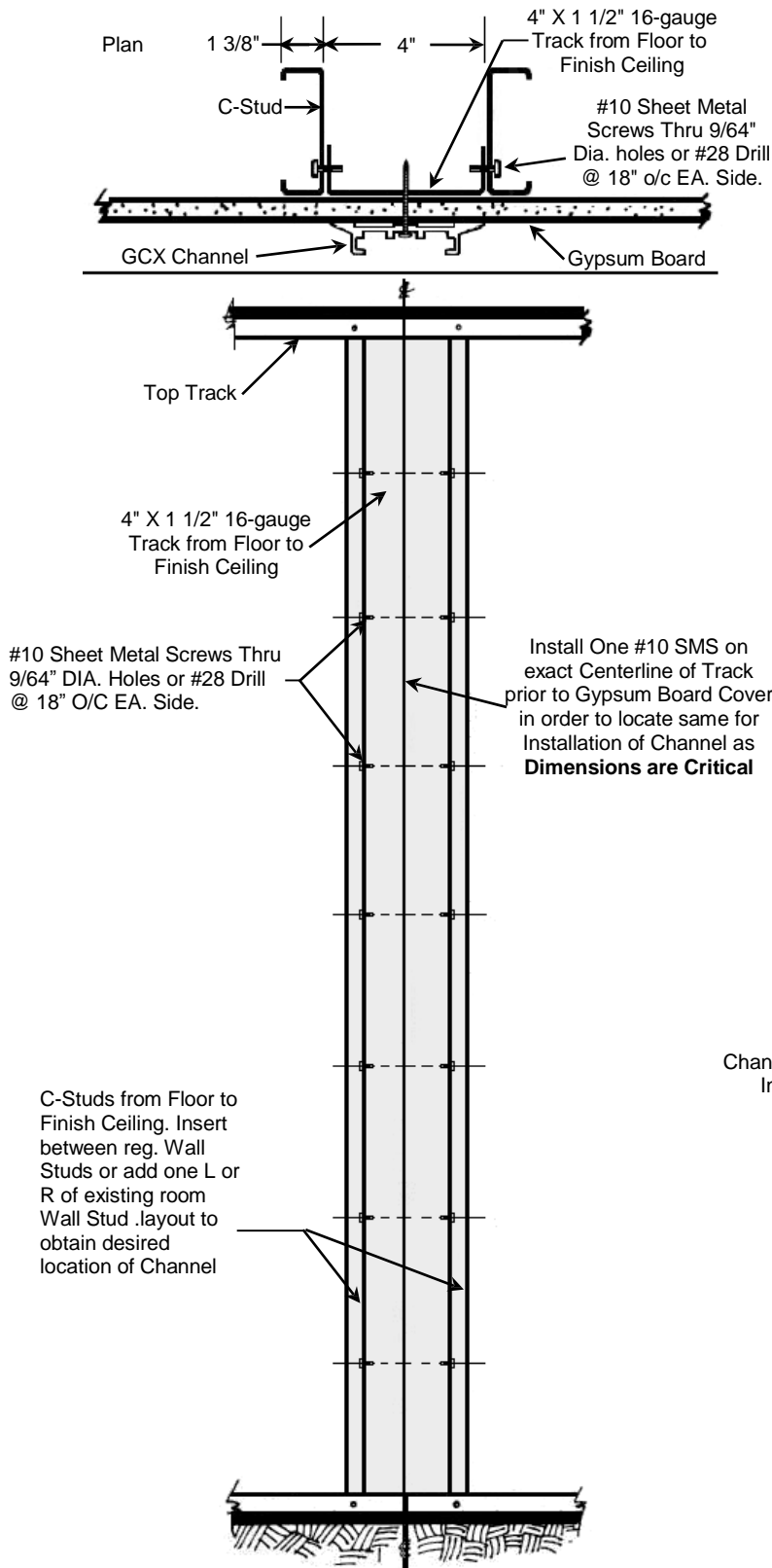

This anchorage will allow for a quick and simple installation of the Standard Wall Channel. 16-gauge steel will prevent the material from extruding up the shank of the screw (Stripping). 11/64" diameter holes are required for #12 X 2-3/4" High Tensile, Phillips Head Screws (4) installed down the Centerline (Non-Seismic Applications).

A second Track can be used for back-to-back Installations. A 2" X 4" wood stud may be used if allowed by local building codes.

Drywall (Gypsum Board) over 16-Gauge Sheet Metal or Wood Studs:

Locate the exact centerline of the stud. Drive a #4 finishing nail through the drywall to contact the stud. Withdraw and drive again 3/8" (9.5 mm) right and left until the edges of the stud have been located and hence the centerline determined. The Wall Channel's 4 inch (10.2 cm) width will cover these exploratory holes.

Drill 11/64" (17 mm) diameter holes for #12 X 2-3/4" high tensile Philips head screws in a single 16-gauge stud through Channel Centerline, (4 places). Install the top screw and level the channel, then mark and drill the other holes.

Drywall (Gypsum Board) over Sheet Metal Studs less than 16-Gauge:

Locate the centerline of the stud per the above instructions. Use 1/4-20 X 3" Pan Head Machine Screws and Toggle Wings. Drill 3/4" (19.5 mm) diameter holes with a sharp speed bore or twist drill (requires pilot hole). Note that the round stop at the bottom of the channel goes over the shank of the bottom screw. Insert screws through Wall Channel holes then affix the toggle wings to the screws. Insert toggle wings into previously drilled holes. Use a level to make sure the channel is vertical prior to final seating of the screws.

Plaster Coat over Expanded Metal Lath on Steel Studs, Hollow Tile, Hollow Block:

Drill 3/4" (19.5 mm) holes. Insert screws through Wall Channel holes then affix the toggle wings to the screws. Insert toggle wings into previously drilled holes. Use a level to make sure the channel is vertical prior to final seating of the screws.

Concrete Walls:

Refer to Structural Engineer.

Through Wall, Back to Back Installations:

Sufficient length 1/4-20 machine screws, nuts, washers and/or back plates must be obtained to mount the channel by drilling all the way through the partition wall. A Portalign drill fixture is recommended for this procedure.

Special Applications:

Channels can be attached to a GCX 4" X 4" (10.2 x 10.2 cm), 1/8" (3.2 mm) wall aluminum support column or certain mullions, etc.. Contact GCX to discuss solutions to mounting concerns for any situation not covered by these guidelines.